

Type 345kV TTR8

2000 / 3000 Amp
80 – 120 kA Momentary

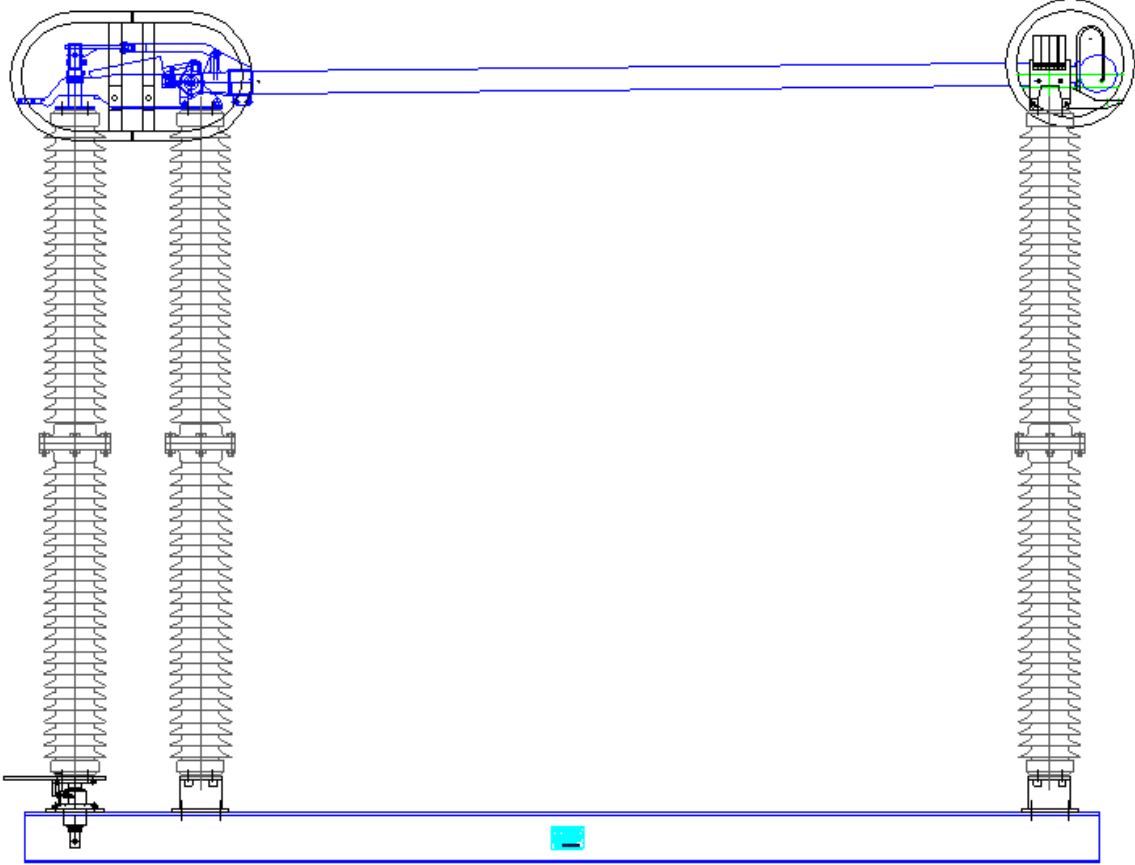

Vertical-Break Outdoor Air Disconnect Switch

Contents

<u>Subject</u>	<u>Page</u>
Receiving and Handling	2
Installation and Adjustment	2
Step 1. Check Bases	3
Step 2. Assemble Insulators	3
Step 3. Insulator Stack Alignment	4
Step 4. Mount Current Carrying Parts	4
Step 5. Switch Blade Adjustment	5
Step 6. Mount Switches	6
Step 7. Mount Offset Bearing	6
Step 8. Adjust Multi-Angle Crank	6
Step 9. Install Vertical Operating Pipe	7
Step 10. Install Pipe Splice and Guide Plate	7
Step 11 Install Offset Rod	7
Step 12. Install Operating Mechanism	7
Step 13. Adjust Drive Phase	8
Step 14. Install and Adjust Interphase Rods	9
Step 15. Arcing Horn Installation	10
Step 16. Installation of Corona Rings and Balls	10
Step 17. Final Checks	11
Switch Adjustment Tips	13
Trouble Shooting	14
Terminal Connections	17
Maintenance	17
Renewal Part	18

Suggested Tools

- 15/16" Open-End Wrench
- 15/16" Socket
- 3/4" Open-End Wrench (2)
- 3/4" Socket
- 1 1/2" Open-End Wrench or Adjustable
- Lineman Pliers
- Tape Measure
- Angle Finder
- Metal Cutting Saw
- Level

IMPORTANT: Read manual before installing or maintaining equipment! Make absolutely sure that equipment is de-energized and properly grounded.

This manual should be used in conjunction with the factory drawings. The drawings contain critical information, which if not followed could affect the operation of the switch.

Instructions cannot cover all possible variations in equipment nor provide for every possible contingency to be met in connection with installation, operation or maintenance. Should further information be required or should particular problems arise which are not covered sufficiently for the purchaser's purposes, the concern should be referred to the factory.

For Technical Assistance Call 276-688-3328

RECEIVING INSPECTION

Check the shipment for completeness against the bill of material and installation drawings. If damage is found, file a claim immediately with the transportation company and notify your Pasacor Atlantic representative.

HANDLING

Handling of disconnect switches should be done with care. Porcelain is fragile and may be damaged due to improper handling.

Factory drawings should be followed during installation. It is recommended that switches be fully assembled and adjusted at ground level before being placed into position. This should minimize final adjustments.

Lifting of switches by insulators, contacts, or live parts should be avoided, because of possible damage to these parts. Attachments for hoisting should be made to the switch bases unless otherwise instructed. (See Fig. 1)

INSTALLATION AND ADJUSTMENT

CAUTION: When uncrating switches, open the switch blade to relieve the pressure of the counterbalance before removing the live parts from the base.

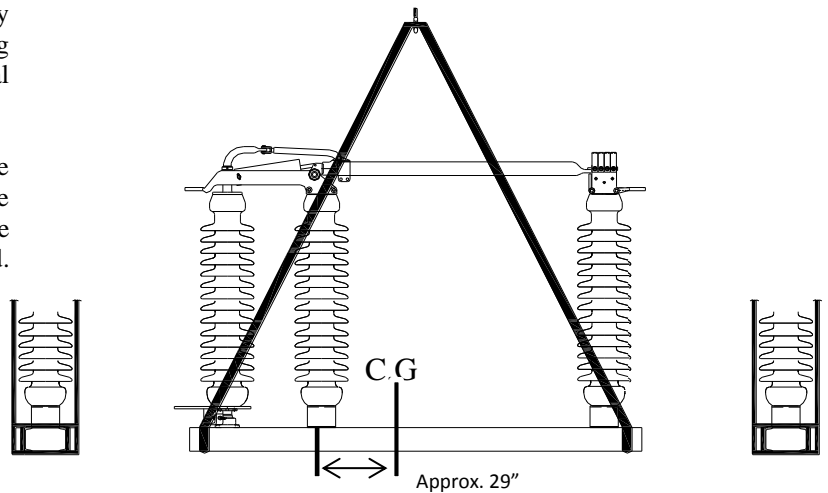

Fig. 1 Proper Rigging for Vertical Break

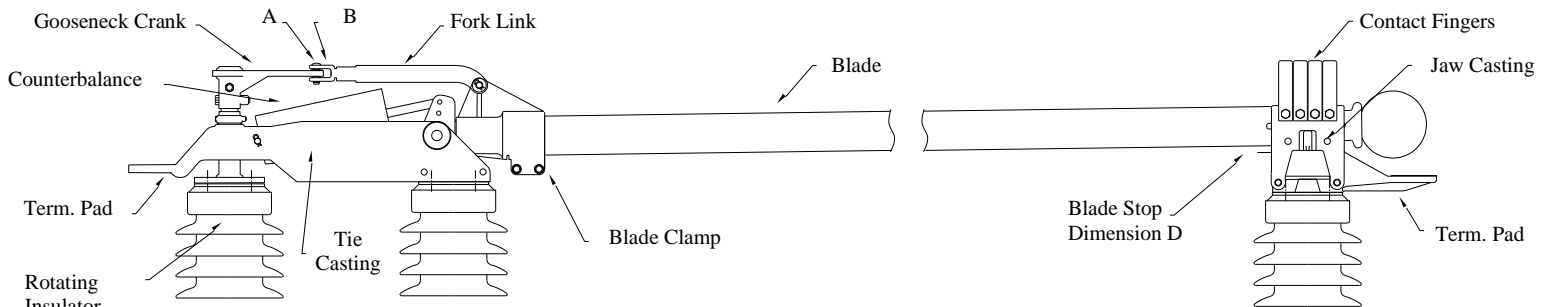
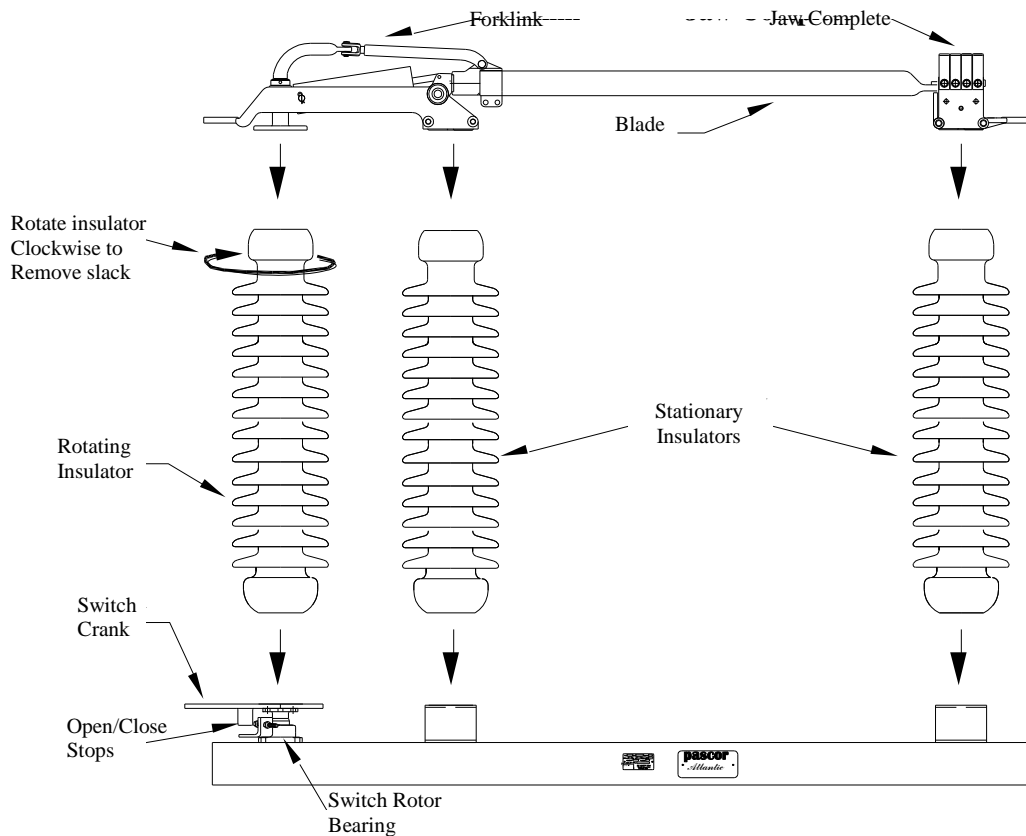

Fig. 2 Typical Set of Current Carrying Parts

Verify Structure is Leveled and Plumb ***IMPORTANT*** **STEPS 1 - 4**
 Mounting Holes Match Instillation Drawings

**Assemble Single Pole
 Plumb Insulators**



Center Blade in Jaw

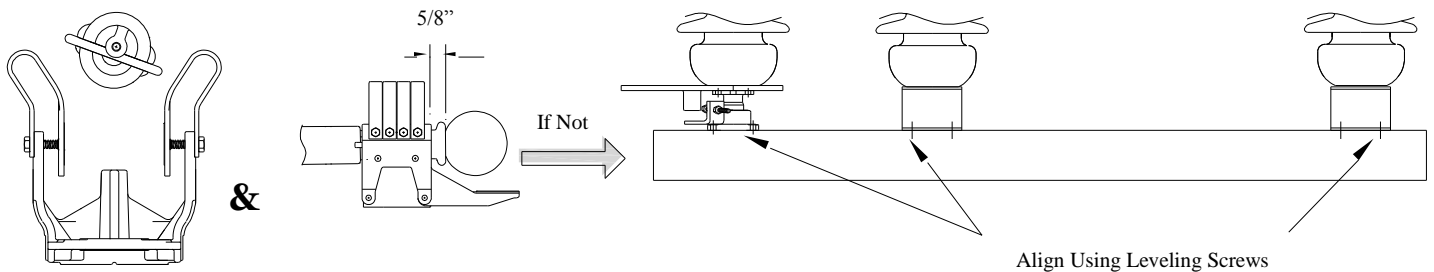

Step 1—Check Bases

Check bases to make sure that the spacers and rotor bearing tops are square and level. The tops of the two supports on the hinge end must be exactly the same height. If necessary, make adjustments using the leveling screws, and adjusting nuts are shown in step 3.

Step 2—Assemble Insulators

Assemble the insulator stacks to switch base. Do not disturb the position of the switch crank when mounting the insulator stack to the rotor bearing, as the crank has been properly located at the factory. In some cases, involving higher voltage switches, the installer may choose to mount the switch bases on the structure before assembling the insulators. In such cases the switch bases should be mounted on the supporting structure in the positions shown on the installation drawing. The bases should be level and parallel to each other. Make sure that the base for the drive phase is in the correct location and operating cranks are at their proper angles. Remove the “slack” from the rotating insulator by rotating the insulator clockwise for all three phases.

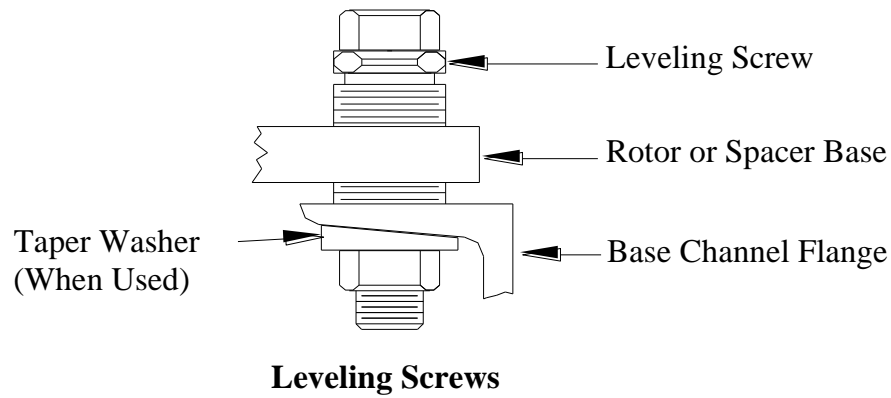

Check Blade Depth In Jaw

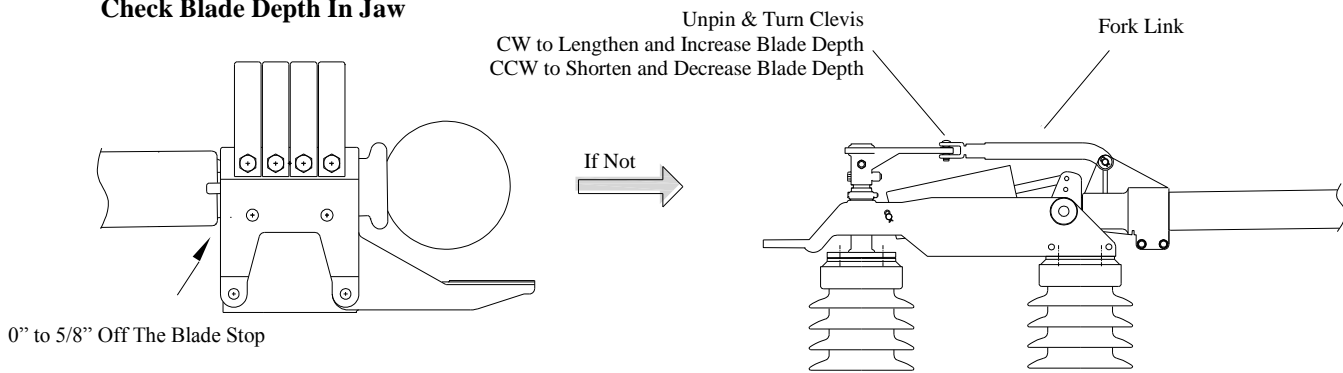

Step 3—Insulator Stack Alignment

The insulator stacks of switches at 345kV can be aligned using leveling screws.

- Leveling screws have been supplied as shown above. Adjust the leveling screw to align the insulator stacks. Loosen all hardware before jacking to prevent binding.

Step 4—Mount Current Carrying Parts

Make certain that the base crank is in the proper position when mounting current carrying parts, i.e. base crank rotated to the maximum clockwise position with the blade open. When assembling the jaws on the insulator columns, leave the mounting bolts finger tight. This will permit the jaw base to be rotated and shifted slightly for subsequent contact alignment. This alignment will be discussed later under blade entry (step 5).

Note: The counterbalances are assembled at the factory, no adjustment to the counterbalance is required.

STEP 5

Check Blade Angle

Blade Angle Tolerance is $\pm 4^\circ$

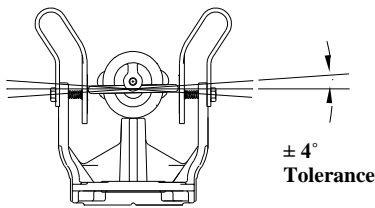

If Not
Adjust Close Stop

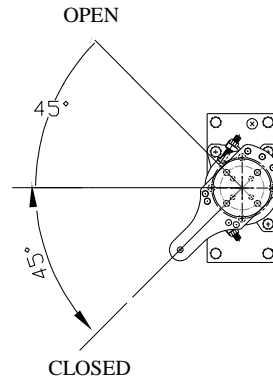

Check Blade Opening

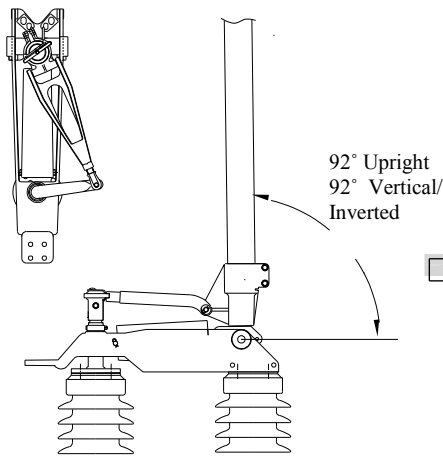

If Not

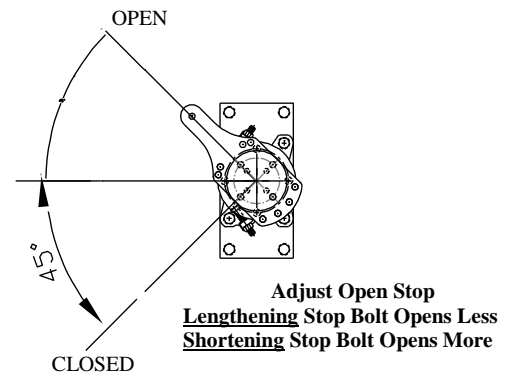

Step 5—Switch Blade Adjustment

When looking down on the single pole's rotating insulator stack, rotate the stack clockwise to open and counter-clockwise to close the switch. First, make sure that stop bolts at base of rotating insulators do not prevent switch from traveling to the complete open and closed positions, then check each pole unit for the following items:

Blade Entry—Lower the blades slowly to the closed position to see if blade contact enters the jaw in a central position. If it does not, loosen the hinge assembly mounting bolts on stationary insulator stack and with blade just out of the jaw, shift blade into alignment and tighten hinge assembly mounting bolts. Should this fail to give proper blade entry, the jaw insulator stack should be shimmed or adjusted to suit. When central entry is achieved, rotate the blade into contact and tighten jaw base mounting bolts. Also make certain the jaw fingers are nearly centered on the blade end contact.

Important: If it is expected that the conductors to be attached to the switch jaw will impose an appreciable horizontal force, it is recommended that the jaw insulator column be adjusted so that the jaw fingers are slightly off center on the blade contact, in a direction toward the hinge end.

Blade Contact Angle—The allowable difference in elevation from one side of the blade contact to the other (dimension X) is $1/16''$ for each $1''$ of contact width. Example: If contact width (A) is $4\ 1/2''$, then dimension (X) can be as much as $9/32''$ and still be within the plus or minus 4 degree tolerance.

Also, the blade contact shown in the diagram is high on the right and low on the left. The reverse is also acceptable, high on the left and low on the right. It is common to have both situations on one three-pole switch. In fact, after all three poles have been adjusted in the open position, and then closed, you may find that one pole will be high on the right, one fairly level and one high on the left. This is due to many variables and tolerances plus the free play or clearance in pin connections of all the switches and control parts.

With the switch blade in the closed position, the gooseneck crank arm and fork link will over-toggle to the left of the switch center line when looking from hinge to jaw end of the switch phase.

Note: switch blade angle in the blade clamp is set in the factory. This is not an adjustment point for blade contact angle.

Blade Height in Jaw—In Fig. 2, dimension (D) can vary from $0''$ to $5/8''$ with the switch in the closed position. It is not usually possible to get this dimension to be equal on all three poles of a three-pole switch. If it's necessary to adjust this dimension, remove connecting pin (A) and turn clevis (B) in or out $1/2$ turn then reconnect and try switch. Turning the clevis in will move the blade away from the blade stop. Conversely, turning the clevis out will move the blade closer to the blade stop.

Note: clevis assembly is a left hand thread connection

Install Single Poles on Structure

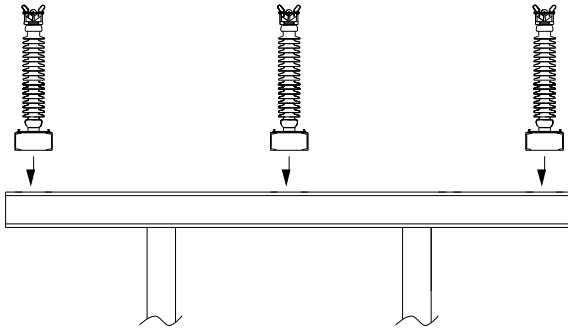

Mount Offset Bearing

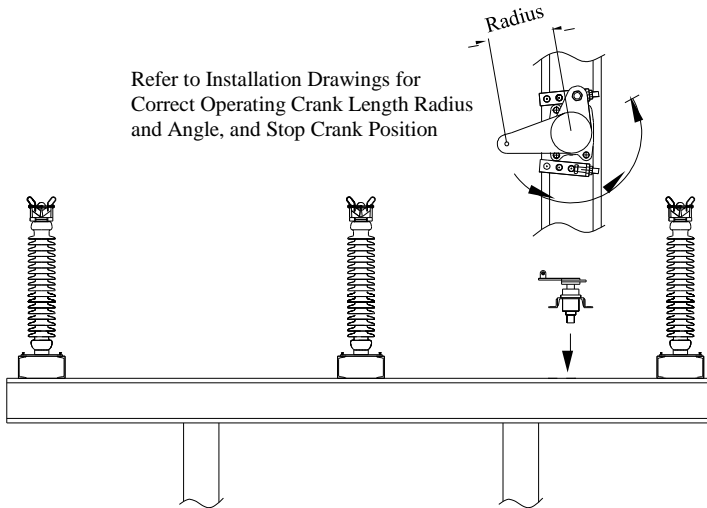

Install Multi-Angle Crank
Refer to Installation Drawings For Correct Setting

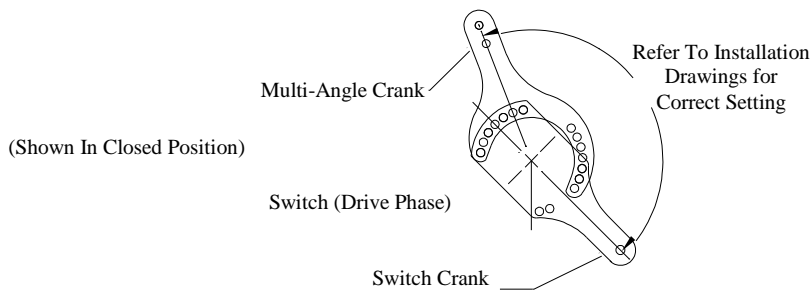

Step 6—Mount Switches

Assemble the switches on the supporting structure in accordance with the positions shown on the installation drawing. The switches should be mounted level and parallel with each other. In case of a warped structure, shimming under the switch bases may be required. See Fig. 1 for proper rigging.

Step 7—Mount Offset Bearing

For those installations requiring an offset bearing, mount the offset bearing and its supporting base on the structure in the position shown on the installation drawing. Pg. 16 shows a typical arrangement using the offset bearing. Check operating crank for proper length radius and angle, and stop crank for correct position. These are defined in the notes on the installation drawing.

Step 8—Adjust the Multi-Angle Crank

The crank is identified in Fig. 3 and is shown in more detail above. This crank is supplied on the operating pole unit connected to the offset bearing. For all custom installations the angle between the multi-angle crank and switch crank is set in the factory when single pole assembled.

The multi-angle crank adjustment is located every 12 degrees which results in adjustments to within 6 degrees of the desired position.

In some adjustments, the multi-angle crank may be in such a position as to interfere with the stop projection on the switch crank. If this is the case, then remove this projection. The other two poles will regulate the blade travel on this unit.

Note: The multi-angle crank should be set so that it forms an angle of approximately 45 degrees with the offset link in either switch position, open or closed.

**Install Vertical Operating Pipe
Install Pipe Splice, Bearing Plate, Position
Indicators, and Ground Strap**

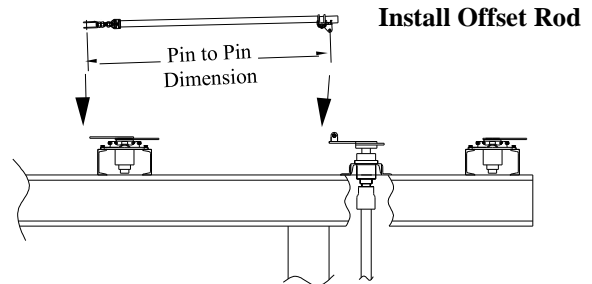
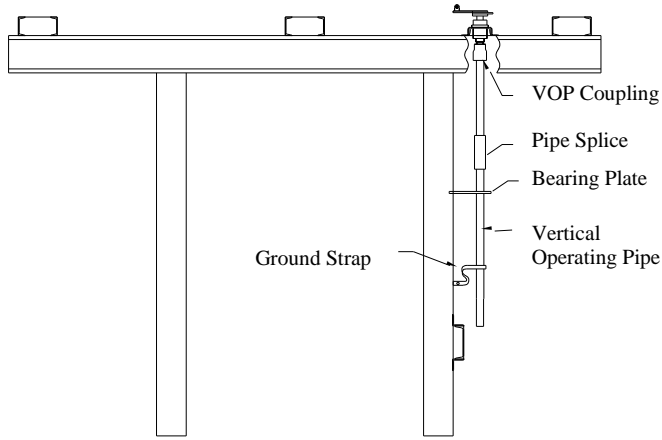

Pin to Pin dimension is Located on Instruction Drawing

Install Operator

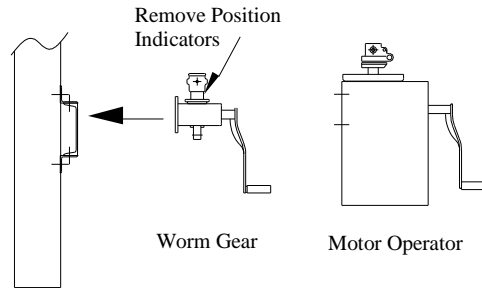

STEPS 9 - 12

Step 9—Install Vertical Operating Pipe

The vertical operating pipe is pre-drilled at one end for a 5/8-inch diameter bolt. To install the vertical operating pipe (VOP):

1. Install the coupling on the VOP, then fasten the VOP to the offset rotor bearing shaft (or on the pole unit rotor bearing shaft for direct-connected switches) using the 5/8" coupling bolt supplied with the unit.
2. Install accessory items. Refer to the drawings shipped with the unit for instructions on installing accessory items (auxiliary switches, mechanical interlocks, position indicators, ground straps, etc.) which mount on the vertical operating pipe.

Step 10—Install Pipe Splice and Guide Plate

A pipe splice and guide plate are furnished for structures taller than 23 feet.

1. Install the pipe splice.
2. Mount the guide plate.
3. Align the hole in the guide plate with the normal position of the vertical pipe without any binding and tighten the bolts on the guide plate.

Step 11—Install Offset Rod

With the drive phase in the fully closed position, install the offset rod from the offset bearing to the multi-angle crank as follows:

- a. Attach the overhead clevis and vernier clevis
- b. Set the pin to pin dimension.
- c. Lengthen the offset rod that is in compression during opening, as much as possible, yet allowing for the pin to be inserted.
- d. If the offset rod is in tension during opening, shorten it as much as possible, yet allowing for the pins to be inserted.
- e. To adjust the offset rod length, loosen the locking nuts and rotate the turning nut shown on page 8 to lengthen or shorten the offset pipe. Then tighten the locking nuts.

The vernier adjustment is for fine tune adjusting. If major adjustment (more than 1") is required, make changes at the overhead clevis mounted on the offset bearing.

Step 12—Install Operating Mechanism

One type of manual operating mechanism is available for the 345kV TTR8 Switch:

- Worm gear mechanism

A motor operator also can be supplied for remote operations.

Worm Gear Mechanism

1. With ground strap in place on vertical operating pipe, slide worm gear mechanism over the vertical operating pipe and attach it to the structure.
2. Remove the small position indicators, which are attached to the worm gear coupling with Allen set screws.
3. Tighten hex head set screws in the coupling until the vertical operating pipe is pierced.
4. If all stops at switch elevation have been set, including the offset bearing, then it is safe to reinstall the position indicators on the worm gear mechanism. These indicators should not quite touch the raised boss on the worm gear housing in either the open or closed position. There is a possibility of damage to the indicators or the coupling if this is not observed

Motor Operator

For remote operation, a motor operator is supplied and it should be installed per the instructions supplied with the unit.

Dead Center ~ "Toggle"

STEP 13

- Offset Bearing Crank Travels Past Dead Center
- When Operating the Switch, the Offset Bearing Should "Snap" Over Dead-Center in the Closed and Open Positions This is Also Referred to as Toggle. This Serves as a Signal to the Operator That the Switch is Either Fully Open or Closed. This is Also a Safety Feature that Insures the Switch is Locked Either in the Open or Closed Position.

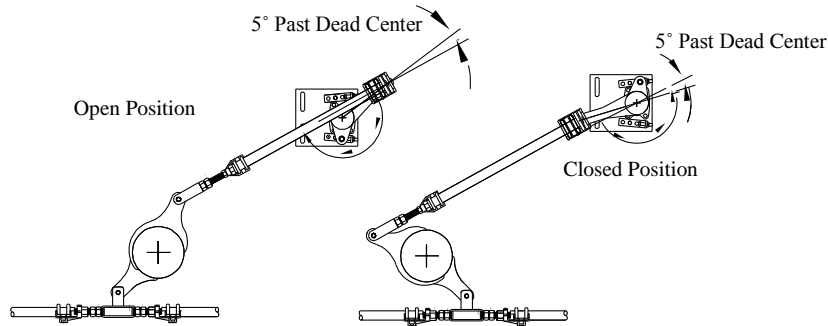

Adjust Drive Phase

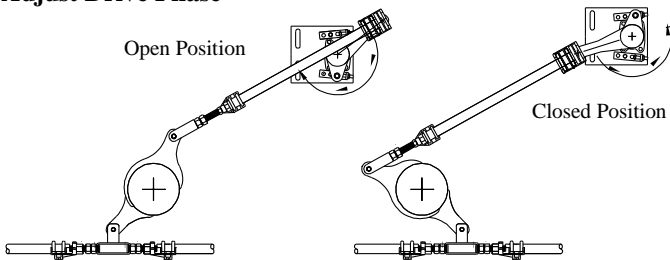

Pulling Switch Open

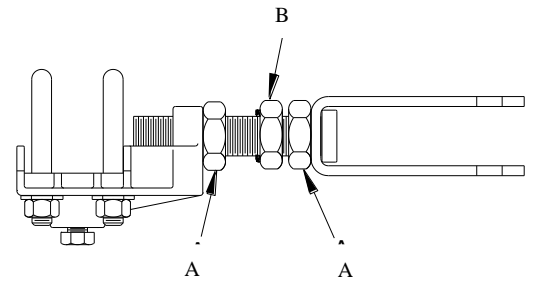

**Vernier Adjustment
On Offset Rod**

Shortening Offset Rod

- Reduces toggle pressure in closed and adds pressure to open position.
- Increase blade opening and decrease blade closing.

Lengthening Offset Rod

- Reduces toggle pressure in open and adds pressure to closed position.
- Increase blade closing and decrease blade opening.

Adjust Drive Phase

The adjustable radius crank adjustment increases or Decreases throw to the open and closed position.

- Lengthening increases travel and toggle pressure in open and closed.
- Shortening reduces travel and toggle pressure in open and closed.

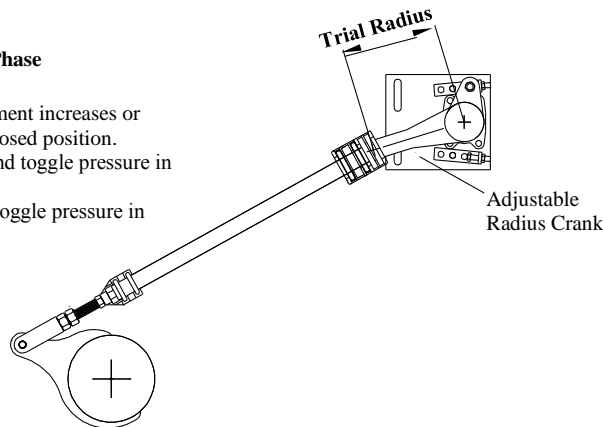

Step 13—Adjust Drive Phase

With the interphase linkage disconnected, make adjustment to the offset rod and offset bearing to obtain your fully open and closed positions, and toggle on your offset bearing. Details of adjustment are discussed on the next page.

The Adjustable Radius Crank is located on the offset bearing. It is used to adjust the total degrees of opening or closing of the switch and to increase or decrease the toggle pressure.

If the toggle pressure is the same in the open and closed positions, and the switch doesn't open and close all the way. Then, lengthen the adjustable radius crank. If the toggle is too hard in both directions, then shorten the adjustable radius crank.

Note: you will see some deflection in the structural members when the crank crosses the dead center position

STEP 14

Install Interphase Linkage

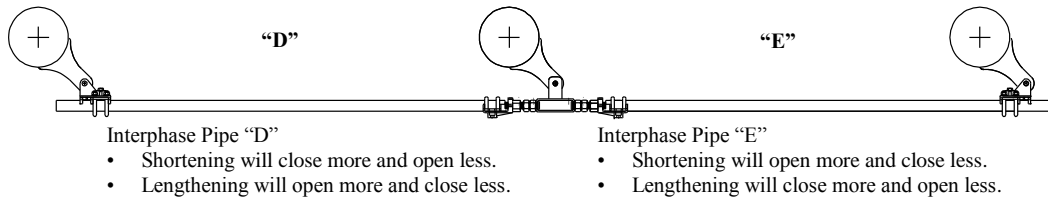
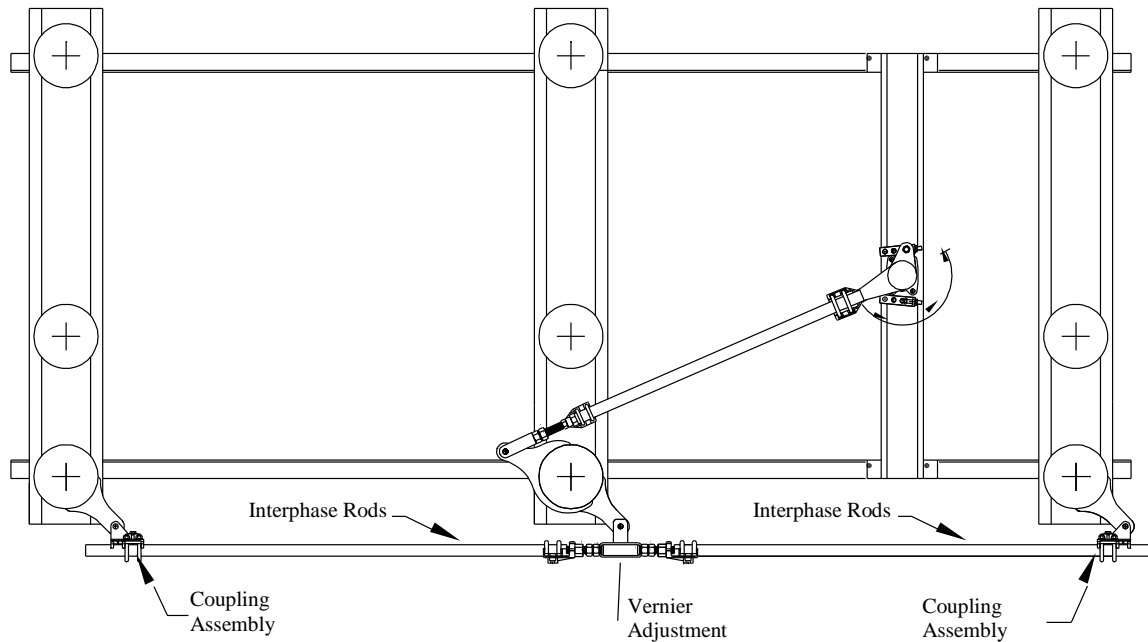

Step 14—Install Interphase Rods

The Interphase pipe operates the three phases in unison. The interphase pipe should be installed after the drive phase is adjusted for proper open and closed blade positions and toggle.

With all blades in the closed position, install the interphase rods and offset crank rod as follows:

- Lengthen the interphase rods that are in compression during opening, as much as possible, yet allowing for the pins to be inserted.
- On the rods that are in tension during opening, shorten them as much as possible, yet allowing for the pins to be inserted.

The vernier adjustment is for fine tune adjusting. If major adjustment is required, make changes at the end phase coupling assemblies.

Interphase pipe “D”

- Shortening the interphase pipe between phase “A” and the center phase will close the switch more and open the switch less.
- Lengthening the interphase pipe will open the switch more and close the switch less.

Interphase pipe “E”

- Shortening the interphase pipe between phase “C” and the center phase will close the switch less and open the switch more.
- Lengthening the interphase pipe will open the switch less and close the switch more.

STEPS 15 - 16

Install Arcing Horns and Corona Rings

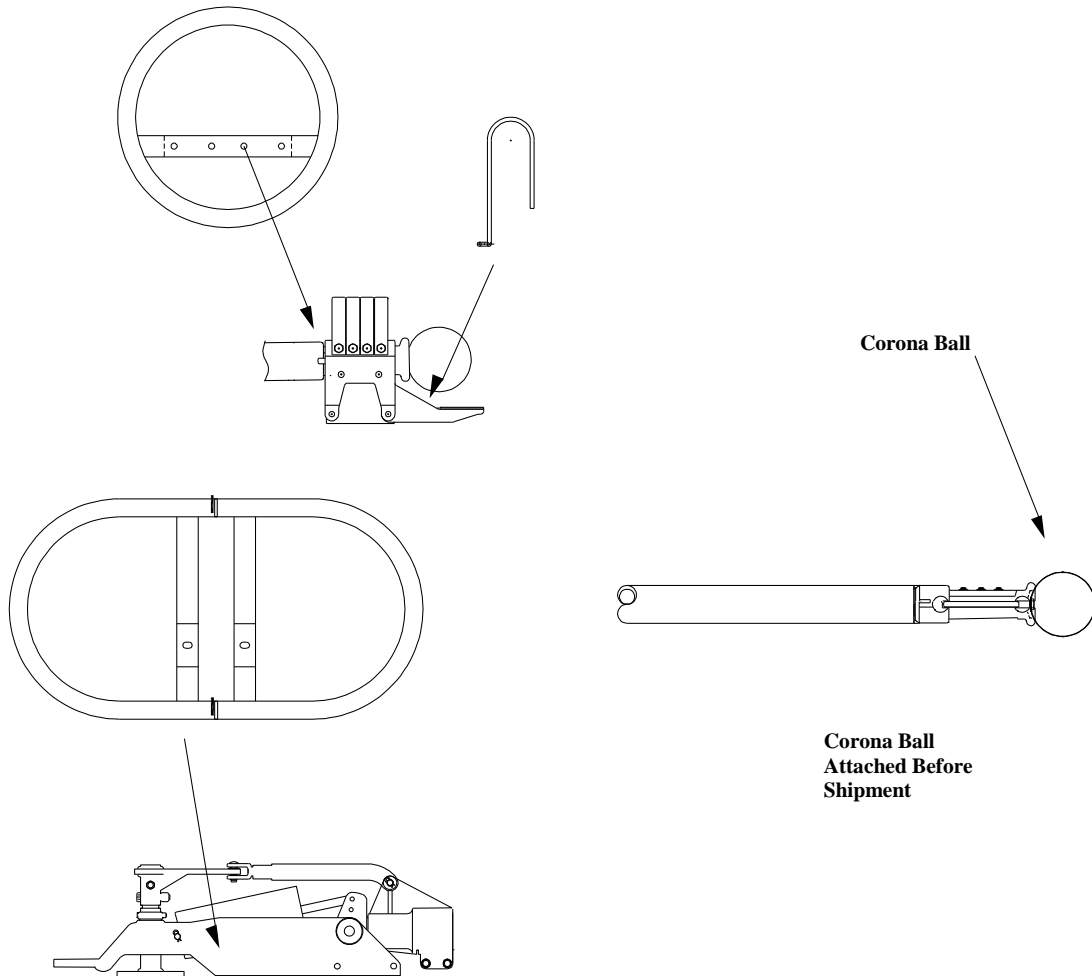

Step 15—Arcing Horn Installation

Arcing horns consist of a stationary horn, and utilization of the blade corona ball for the moving contact. If arcing horns have been supplied, install and adjust them after mounting the switches on the structure.

To install the stationary horn:

1. Bolt the stationary horn on the jaw with the saddle clamp.
2. Adjust or slightly bend the stationary horn to apply light contact pressure between the two horns over the entire length of the stationary horn.

Step 16—Installation of Corona Rings and Balls

The 345kV switches utilized corona rings at the jaw and hinge end of the switch.

Install corona rings and ball components as shown on the single pole drawings after mounting the switch to the structure.

Important: Prepare areas where ring supports contact switch parts as per instructions for aluminum-to-aluminum connections on page 17.

STEP 17

Final Checks

A. Blade Centered in jaw

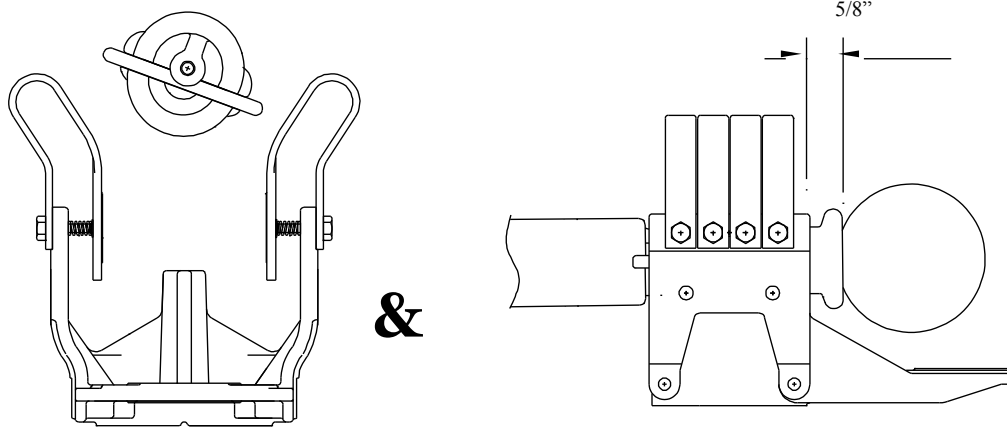

B. Blade Contact Angle is $\pm 4^\circ$ in Jaw

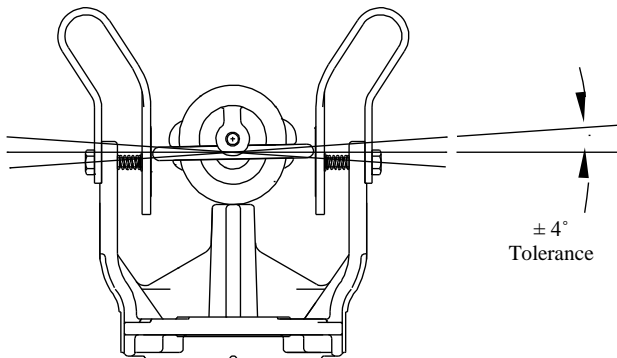

C. Blade is 0" to 5/8" Off the Blade Stop

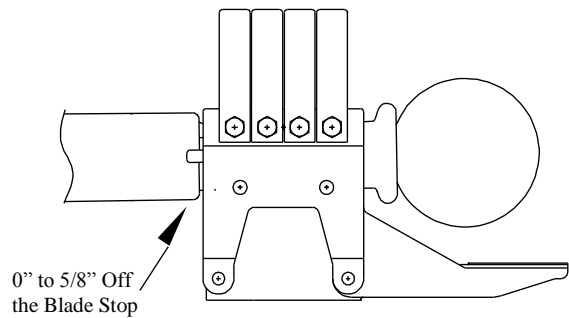

Step17—Final Checks

The completed 3-blade installation should be checked for the following:

1. In the open position, the blades should be between 90° to 93° .
2. In closing, blades should make central entry into their jaws at approximately the same time.
3. In the closed position, all blades must be in full contact and horizontal within tolerances, see page 5.
4. All jaw mounting bolts are tightened with switch in close position.
5. In opening, the blades should rotate to relieve the jaw contact pressure.
6. Tighten all lock nuts and pierce bolts.
7. For worm gear operating mechanisms:

If all stops at switch elevation have been set, including the offset bearing, then it is safe to reinstall the position indicators on the worm gear mechanism. These indicators should not quite touch the raised boss on the worm gear housing in either the open or closed positions. There is a possibility of damage to the indicators or the coupling if this is not observed

STEP 17 Cont.

D. Blade Opening

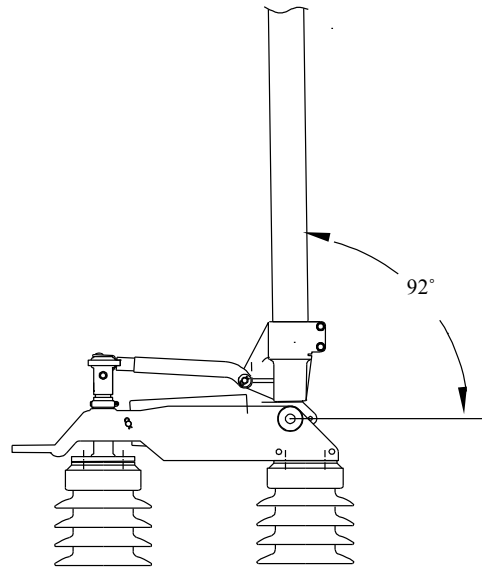

E. The Offset bearing toggles in the open and close position.

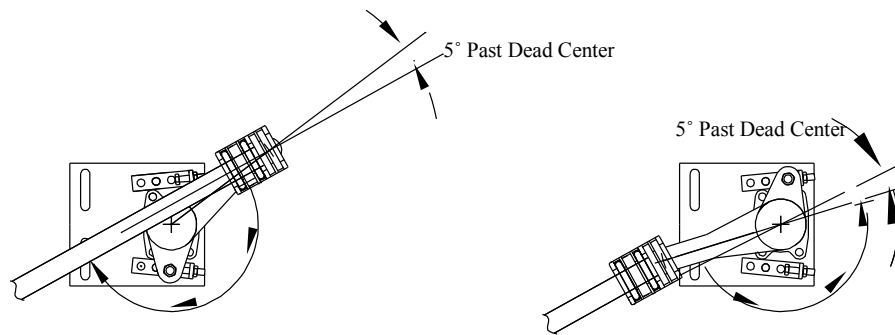

F. All jaw mounting bolts are tightened with switch in closed position.

G. Tighten all locking nuts and piercing bolts.

H. For worm gears – Position indicators are installed.

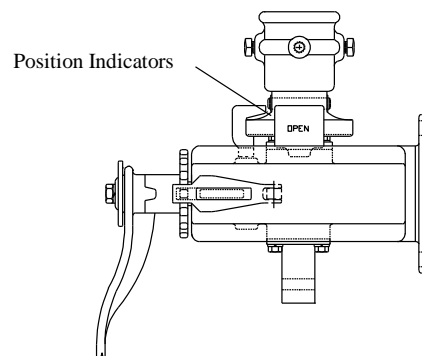

Switch Adjustment Tips

The section will cover the concepts to properly adjust your switch.

When operating the switch, the offset bearing should “snap” over dead-center in the closed and open positions. This is also referred to as toggle. This serves as a signal to the operator that the switch is either fully open or closed. This is also a safety feature that insures that the switch is locked in the open and closed positions.

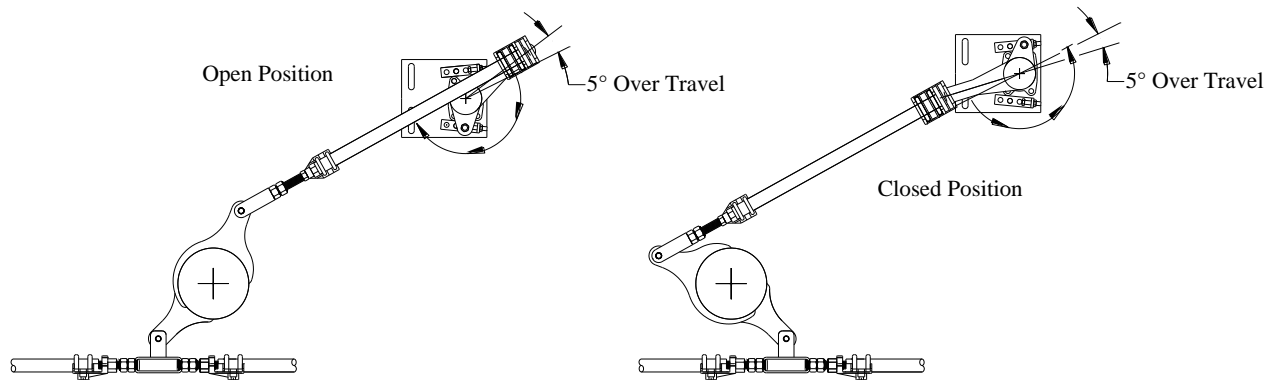

Fig. 3 Pulling Switch Open

Adjustments can be made to the offset rod to equalize the toggle in the open and closed positions. A change in the offset rod length will also affect the final position of the open or closed switch blade as described below:

If the offset bearing is *pulling* the switch open (Fig. 3):

- Shortening will reduce toggle pressure in the closed position and add in the open position. It may also decrease blade roll in on close and increase blade open angle.
- Lengthening will reduce the toggle pressure in the open position and add to the close position. This should increase the blade roll in on the close position and decrease blade open angle.

If the offset bearing is *pushing* the switch open (Fig.4):

- Shortening will increase toggle pressure in the closed position and decrease in the open position. This should increase the blade roll in on the close position and decrease blade open angle.
- Lengthening will reduce the toggle pressure in the close position and add to the open position. This will decrease blade roll in on close and increase blade open angle.

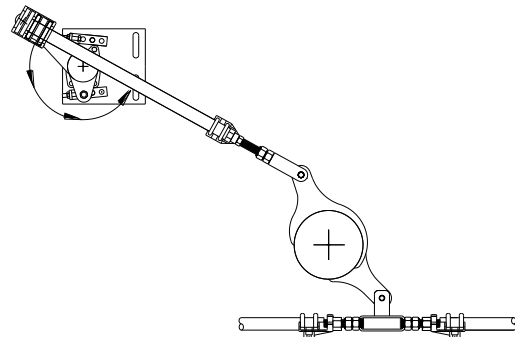

Fig. 4 Pushing Switch Open
(Shown in Closed Position)

Trouble Shooting Guide

<i>CONCERN</i>		<i>ACTION</i>	
Blade doesn't open to 90 degrees	Is this at the single pole assembly level?	If so then:	If the angle is less than 90°, locate the open stop bolt at the base of the rotating insulator (Left hand side). Loosen the jam nuts on the stop bolt and turn the bolt inward until the 90° angle is obtained. Proper adjustment of the switch in the open position is accomplished when the moving contact or "beavertail" is at a 90° +3°/-0°. If the angle is more than 90°, locate the open stop bolt at the base of the rotating insulator (Left hand side). Loosen the jam nuts on the stop bolt and turn the bolt inward until the 90° angle is obtained. Proper adjustment of the switch in the open position is accomplished when the moving contact or "beavertail" is at a 90° +3°/-0°.
	Is it in the 3 phase arrangement?	If so then:	If the switch does not fully open to 90° make sure that the outboard bearing traveled the complete 190°. If not, loosen the stop bolts and turn inward until the 90° opening can be obtained. If the outboard bearing does travel 190° and the bearing is "pulling" the switch open, lengthen the trail radius crank by 1/4" until 90° opening can be obtained. For pushing the switch open, lengthening the trail radius would also be necessary. (pg. 8 & 9)
Blade isn't completely flat when closed	Is this at the single pole assembly level?	If so then:	If the beavertail is under 0°, locate the closed stop bolt at the base of the rotating insulator (right hand side). Loosen the jam nuts on the stop bolt and turn the bolt inward until the 0° flatness is obtained. Proper adjustment of the switch in the closed position is accomplished when the moving contact or "Beavertail" is at 0° ±4° parallel with the switch base. If the beavertail is more than 0°, locate the closed stop bolt at the base of the rotating insulator (right hand side). Loosen the jam nuts on the stop bolt and turn the bolt outward until the 90° angle is obtained. Proper adjustment of the switch in the closed position is accomplished when the moving contact or "beavertail" is at 0° ±4° parallel with the switch base.
	Is it in the 3 phase arrangement?	If so then:	Manually operate the single pole, driven by the outboard bearing to the closed position. Verify the moving contact or "beavertail" is at a 0° ±4° parallel with the switch base. If the outboard bearing is "pushing" the switch closed, then lengthen the offset rod by using the vernier adjustment until the +4° closing can be obtained. For pulling the switch closed shortening the offset rod should be necessary. (pg. 8)
Blade is too high in the jaw, not in the centerline of the contact springs			If the height is more than the suggested 5/8" off of the stop, lengthen the assembly by turning the clevis clockwise in 1/2 turn increments until the correct height is achieved.
Blade is too low in the jaw, not in the centerline of the contact springs			If the blade is driving into the stop creating a binding situation, shorten the assembly by the turning the clevis counter-clockwise in 1/2 turn increments until the correct height is achieved.
Switch will completely open, but not completely close			Check the degree of angle between the interphase crank and the multi-angle crank on the drive phase. Set to the degree angle indicated on the Control Drawing Plan View.
Switch will completely close but not completely open			Check the degree of angle between the interphase crank and the multi-angle crank on the drive phase. Set to the degree angle indicated on the Control Drawing Plan View.
Outside phase(s) will not completely turn flat.			Typically, it is better to over travel the moving contact on the drive phase to the maximum +4 to allow for any lost motion once the remaining phases are connected. This will allow these phases to fall within the 0 to -4 tolerance.
All three phases are inconsistent, not working together.			Manually operate the switch to open and verify adjustment needs. Fine-tuning of the new phase can be accomplished by slightly shortening or lengthening the interphase rod. Use the vernier adjustment on the center phase to lengthen or shorten the interphase pipe, depending on whether you need more opening or closing. (pg. 9)

<i>CONCERN</i>		<i>ACTION</i>
Blade hits hard against the jaw stop		If the blade is driving into the stop creating a binding situation, shorten the assembly by turning the clevis counter-clockwise in 1/2 turn increments until the correct height is achieved. (pg. 4)
Outboard bearing snaps violently over dead center close only		If the offset bearing is pushing the switch closed, shorten the offset rod. For pulling the switch closed lengthen the offset rod. (pg. 8)
Outboard bearing snaps violently over dead center open only		If the offset bearing is pulling the switch closed, lengthen the offset rod. For pulling the switch closed shorten the offset rod. (pg. 8)
Outboard bearing snaps violently over dead center close and open		Shorten trail radius by 1/4" and retry until offset bearing snaps over dead center but not violently. (pg. 9)

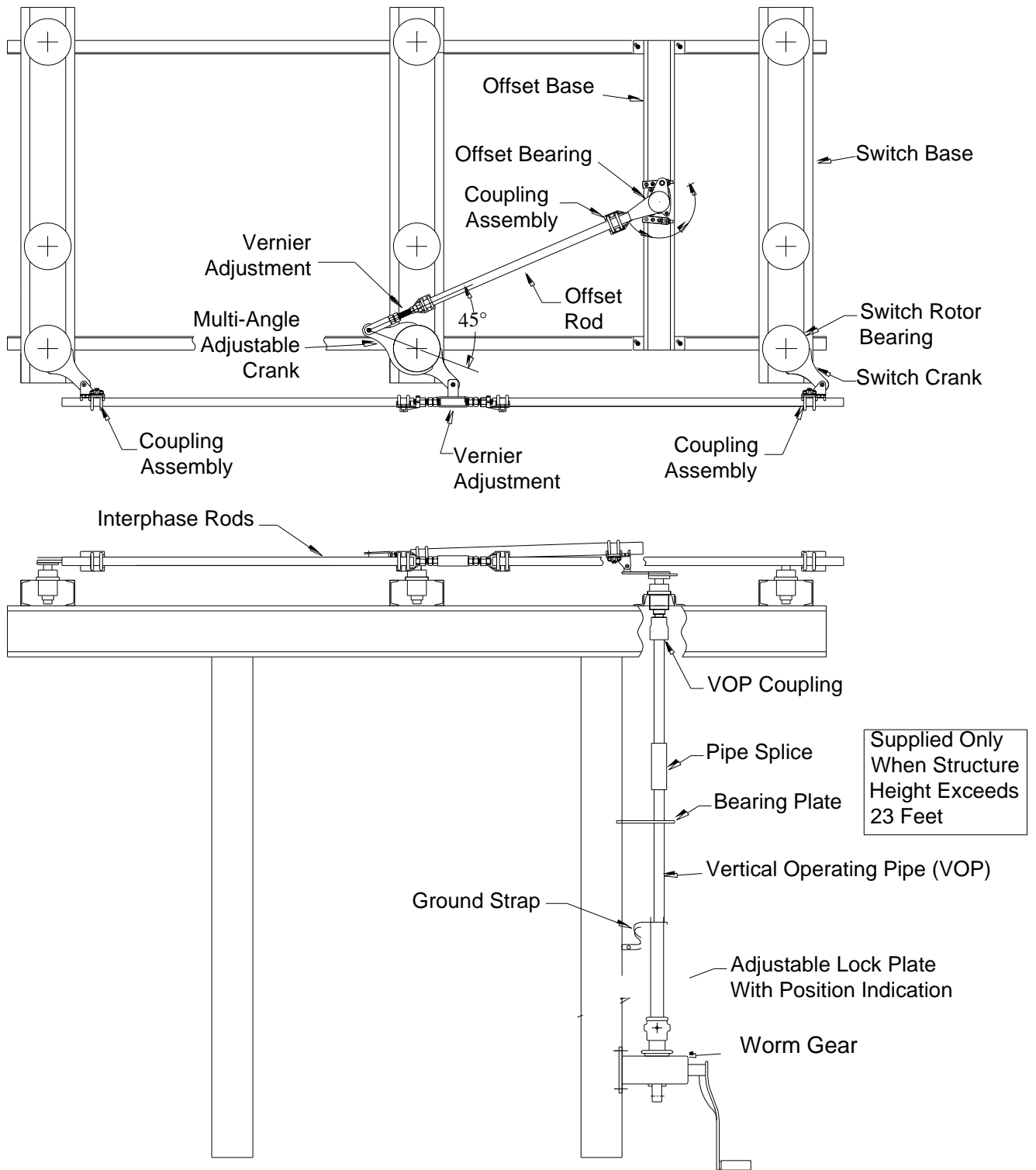

Fig. 5 Typical Three-pole TTR-8 Switch Installation Complete

Terminal Connections

The aluminum surface of the terminal connection provides for easy current transfer.

Notice: In cases where a copper conductor is used, bolt a tinned terminal clamp (if available) to the aluminum switch terminal pad.

If a non-tinned terminal clamp is used, apply a liberal amount of electrical joint grease at the joint and all over the pad of the fitting.

To connect aluminum-to-aluminum terminals:

1. Clean all contact surfaces of conductors and fittings using a stiff wire brush to remove heavy oxide coatings until the aluminum finish is visible and restored.
2. Coat these now clean contact areas with a liberal amount of corrosion inhibitor such as NO-OX-ID™A Special™ or No. 2 EJC.
3. Abrade the contact surface through the corrosion inhibitor again using the stiff wire brush.

Notice: Do not remove the compound.

4. Connect the terminals and torque the bolts as per Table 1.

To connect copper-to-aluminum terminals:

1. Except for plated surfaces, clean all contact surfaces of conductors and fittings using a stiff wire brush to remove heavy oxide coatings until the aluminum finish is visible and restored.
2. Prepare any bare copper surfaces in the usual manner.
3. Coat these now clean contact areas with a liberal amount of corrosion inhibitor such as NO-OX-ID™A Special™ or no. 2 EJC.
4. Abrade the contact surface through the corrosion inhibitor using a stiff wire brush.

Notice: Do not remove the electrical joint grease.

5. Connect the terminals and torque the bolts as per Table 1.

BOLT SIZE	condition of Threads	Recommended torque in Ft. Lbs.			
		Silicon Bronze	Aluminum 2024-t4 anodized	Stainless Steel Type 304	Bright Zinc, Black & Galv. Steel
3/8"-16	Dry Lubricated	20	15	16	12
		15	12	13	10
1/2"-13	Dry Lubricated	40	35	40	30
		30	20	30	20
5/8"-11	Dry Lubricated	70	60	70	50
		50	40	50	40
3/4"-10	Dry Lubricated	100	95	100	90
		85	60	80	70
7/8"-9	Dry Lubricated	150	130	140	130
		120	75	110	100
1"-8	Dry Lubricated	200	160	170	170
		160	95	140	130

MAINTENANCE

WARNING

Before servicing the switch, be sure it is disconnected from all electric power sources and properly grounded.

Maintaining the TTR8 Switch includes inspection. The frequency of inspection depends upon atmospheric conditions and frequency of operation. The service interval is largely determined by the user. Recommended maintenance is similar to that listed in IEEE C37.30.1 ANNEX D.

Complete the maintenance checklist items listed in the table to assure that all proper maintenance is carried out.

Notice: Contaminated environments or operation in sleet conditions also may require applying the lubricants at pivot points. The grease should be durable and able to retain its viscosity over a wide temperature range.

TTR8 Switch Maintenance Checklist	
Item to Check	Check
Under normal service conditions, inspect the jaw contacts at least once a year.	
Examine contacts to be sure that they are aligned, clean, and have a firm uniform pressure.	
If contacts are pitted or burned, remove and replace the old contacts with new ones.	
Clean the contact surfaces thoroughly by scraping off any contamination or deposit.	
After cleaning the contacts, apply a coat of lubricant, either MOBIL 28 Grease or NO-OX-ID Grade "A" Special.	

Field Lubrication of Outdoor Switches

*None required at installation unless switches were exposed to abnormal conditions during storage for a considerable length of time. During regular cleaning, give them a light coat of grease.

Table 2 Lubrication Guide for Outdoor Switch Components			
Part Name	Type Lubricants Recommended	Amount Applied	Qty. Req'd. for (6) Three-pole Switches
Jaw Fingers	NO-OX-ID Grade "A" Special or Mobil 28 Grease	Medium Coat	
Blade Ends	NO-OX-ID Grade "A" Special or Mobil 28 Grease	Medium Coat	(1) Quart
Pins On current carrying parts	Mobil 28 Grease or DC-4	*	
Pins On control parts	Mobil 28 Grease or DC-4	Light Coat	(1) Quart
Bearing Areas On control parts	Mobil 28 Grease or DC-4	Medium Coat	
Terminal Connections	NO-OX-ID Grade "A" Special or NO 2 EJC	Heavy Coat	(1) Quart

RENEWAL PARTS

Refer to the switch nameplate when ordering renewal parts. The nameplate is attached to the base assembly of each switch pole. The same data is shown on the record engineering drawings. The master file at the factory is linked to the serial number on the nameplate.

Renewal Parts Ordering Information

Serial Number
Switch Type
Part Name
Quantity Required
Max. kV
B.I.L. kV
Cont. Amps
Mom. Amps

Refer your requests for renewal parts to the Factory.

Pascor Atlantic
Air Switch Division • State Route 42
254 Industry Dr. • Bland, Virginia 24315-9709
Phone: 276-688-3328 • Fax: 276-688-2228 or 2229
www.pascoratlantic.com



This bulletin describes our standard product and does not show variations in design which may be available. If additional details are required, contact your local Pascor Atlantic representative. Pascor Atlantic reserves the right to make changes or improvements to the product shown in this bulletin without notice or obligation.