

1 MEASURE AND MARK VERTICAL OPERATING PIPE.
(2 3/8" FROM TOP OF WORMGEAR COUPLING)
(5 1/2 " FROM BOTTOM OF PIPE)

2 SUPPORT/CLAMP UPPER SECTION OF VOP TO PREVENT ROTATION.

3 CUT THE VOP AND REMOVE WORMGEAR OPERATOR

4 MOUNT MO-10 MOTOR OPERATOR WITH HALF OF COUPLING REMOVED.

5 INSERT PIPE INTO COUPLING AND INSTALL SECOND HALF OF PIPE COUPLING WITH SUPPLIED HARDWARE.

6 VERIFY MIN OF 1/4" GAP BETWEEN BOTTOM OF VOP AND BOTTOM OF COUPLING

7 PIERCE V.O.P. AFTER ALL OPERATOR ADJUSTMENTS ARE MADE.

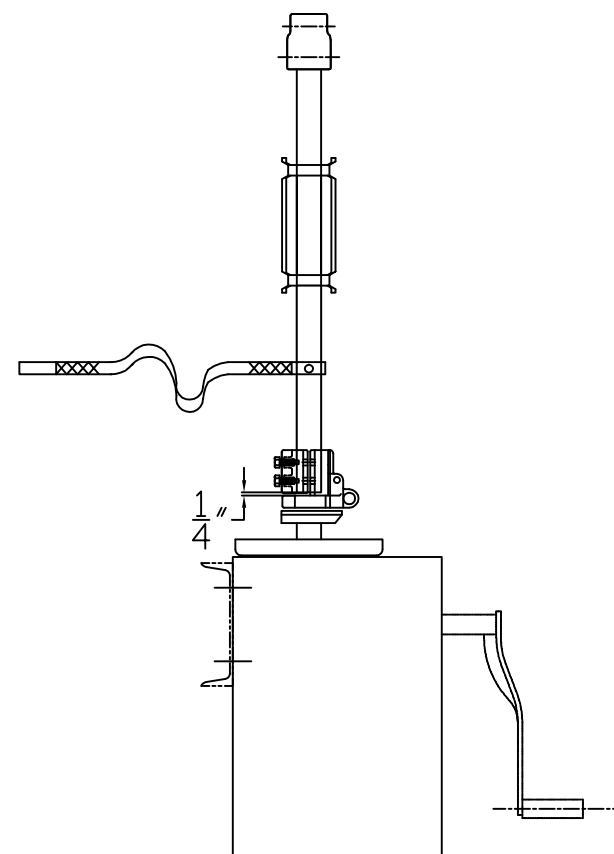
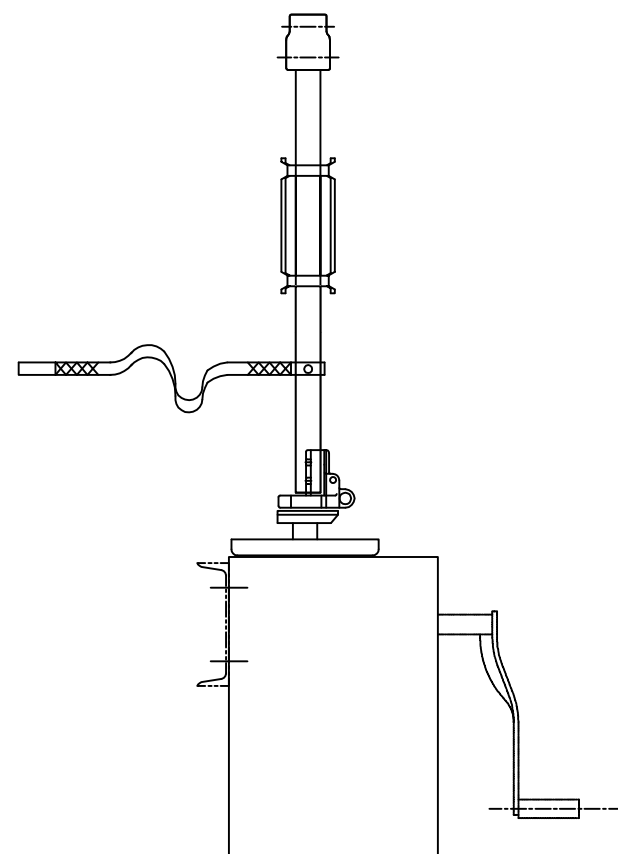
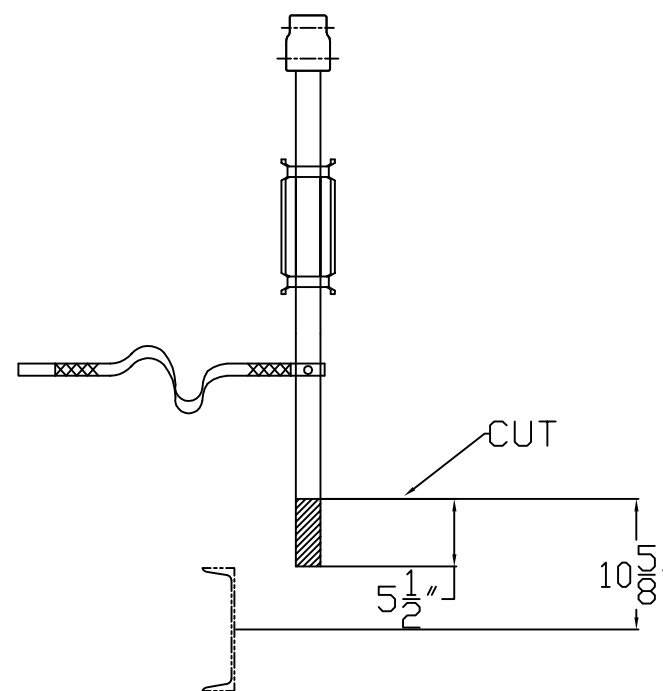

254 INDUSTRY DRIVE, BLAND VA. 24315, 276-688-3328

WORMGEAR FIELD REPLACEMENT TO MO-10 MOTOR OPERATOR

** This manual should be used in conjunction with the factory drawings. To request a set of drawings please have the serial number of the switch and contact the factory at 276-688-3328.